

DATA SHEET

KY-LOC 1D.01.01

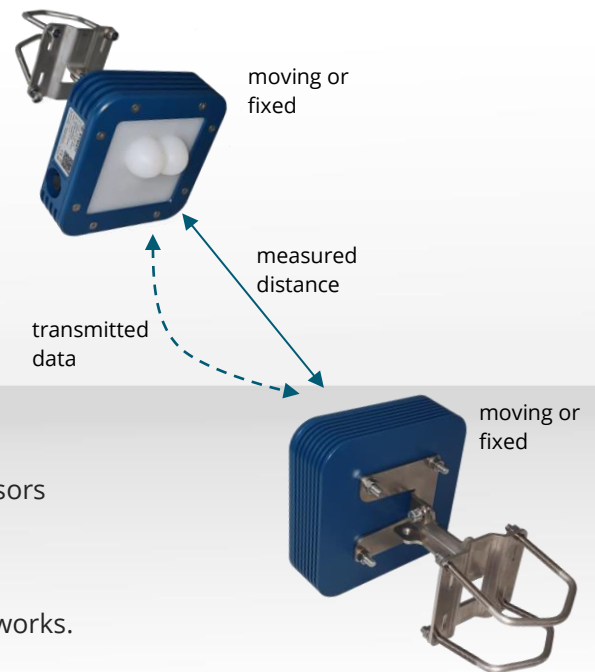

- Precise and reliable distance measurement between two Radar sensors to activate warning thresholds and measure distances.
- Maintenance-free indoor and outdoor operation.
- RF based, no interference with WiFi and mobile communication networks.

COLLISION AVOIDANCE ASSISTANCE SENSOR

TECHNICAL DATA: KY-LOC 1D.01.01

Anti-collision detection range ¹⁾ ;	2m ≤ x ≤ 500 m
Distance measurement range	2m ≤ x ≤ 40 m
Repeat accuracy of measurement ¹⁾	typ. ± 15 mm
Absolute distance accuracy ¹⁾	typ. ± 50 mm
Opening Angle horizontal/vertical	± 7°
Update rate	up to 20 Hz (single side data connection)
User data transfer parallel to measurement	up to 1 kbit/s
Protection	IP 66, IP66k and IP68 (cntd. plugs, 24h@1m)
Operating temperature	-30 ... +75 °C; -22 ... 167 F
Weight, dimensions LxWxD	1060 g; 138x138x43mm (without support bracket)
Voltage, power consumption (M12, 5 pin, male, A-coded)	9 ... 36 V DC or PoE (802.3af), 5 W
Frequency band	61 GHz (ISM band)
Interface (M12, 8 pin, female, X-coded)	Ethernet (100Base-Tx), PoE (802.3af), RS485
Radio compliance	FCC, IC

¹⁾ Values may vary with radio regulations applicable

KY-LOC 1D.01.01- Quick Facts

- Cost effective collision warning devices for any type of moving equipment (e.g., cranes, transfer cars).
- To be used as assistance system, not as single safety device if personal injuries could be possible.
- No precise horizontal or vertical alignment required.
- Parallel wireless user data transmission without the use of WiFi.
- Highly reliable under adverse weather conditions, dust, and dirt.
- User-defined preset distance warnings.
- No interference with WiFi or 5G.
- Multiple KY-LOC pairs can operate in parallel using different channel settings.
- Easy to install, mounting bracket included.
- Maintenance-free.

DATA SHEET

KY-LOC 1D.01.01

Mechanical Interface

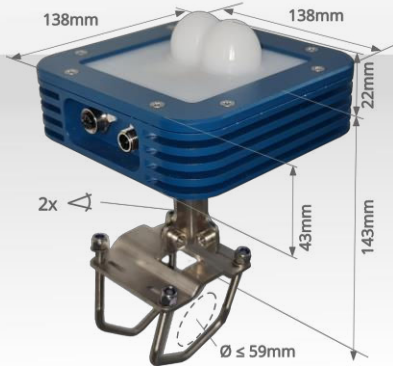

Electrical Interface

- Separate power supply or PoE
- All interfacing options (see below)

- Data interface: Ethernet
- Power: separate power supply or PoE

- Output signal module KY-XTRA B.10.01 with digital output signals based on defined distance warning thresholds

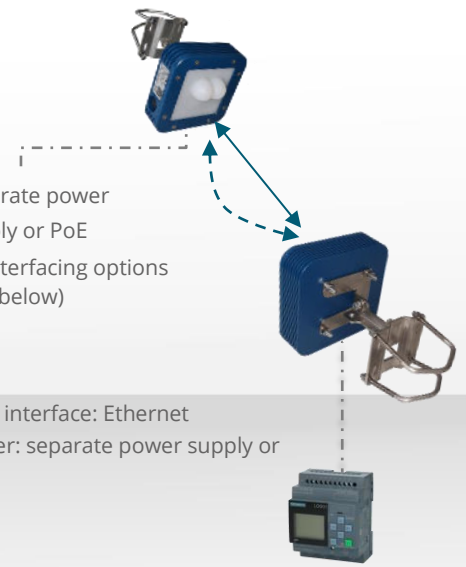

APPLICATION EXAMPLES

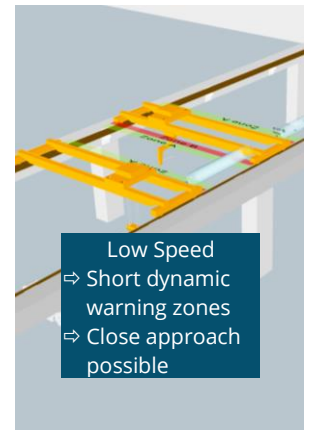
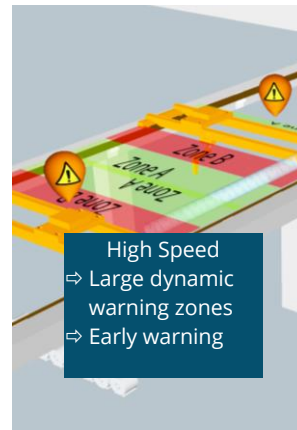
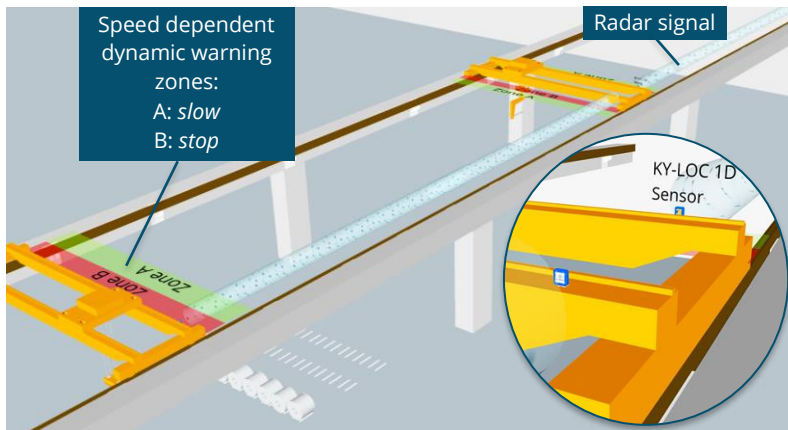

CRANES

- Collision avoidance
- No-go zones
- X-Y-Z axis motion control

FREE RANGING OBJECTS

- Rubber tyre gantries
- Not depending on straight alignment of relative mounting positions

MACHINE ZONE CONTROL

- Any moving machine
- Control zone entry/exit
- Multiple machines/zones

